



HYDRAULIC FLANGE SPREADERS

- For maintenance, valve change outs, commissioning, and testing
- Flange Spreader: Smooth, parallel flange movement opens flanges safely and easily. Low maintenance due to few moving parts.
- Flange spreader fits in gap as small as 6mm (~1/4").
- Flange Holder: Step shaped design allows flange to be held securely open in multiple increments.



HFSS14



MFSS08

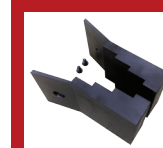

CFSS-02

Use stepped blocks to increase flange opening up to 80 mm. Fits both HFSS14 and MFSS08.



HYDRAULIC FLANGE SPREADERS

CFSS-02

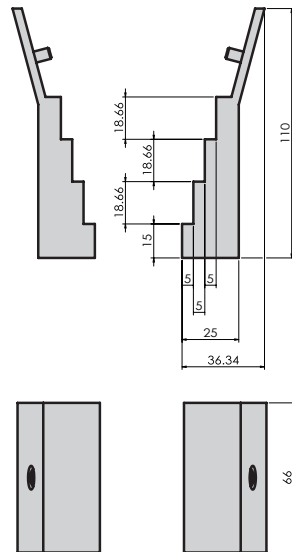

HFSS14

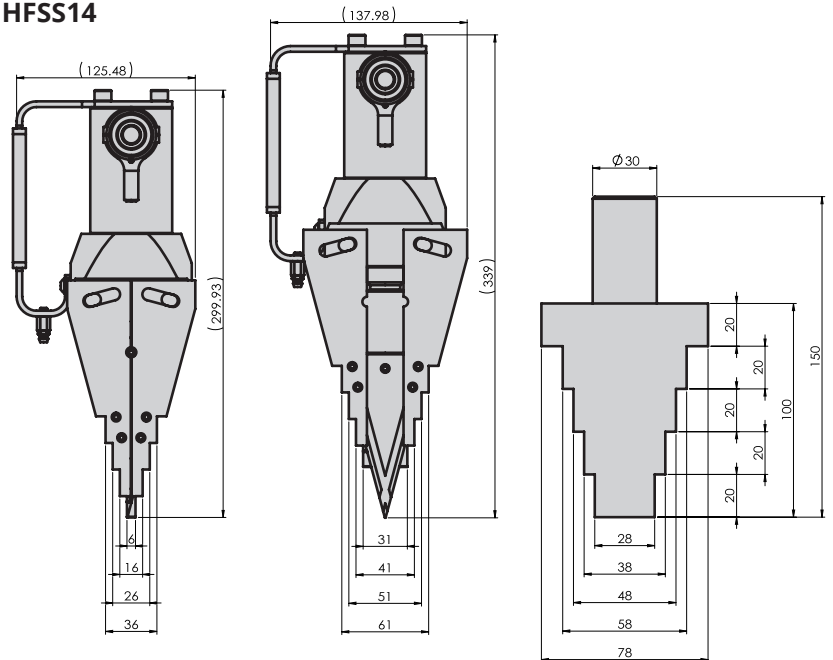

MFSS08

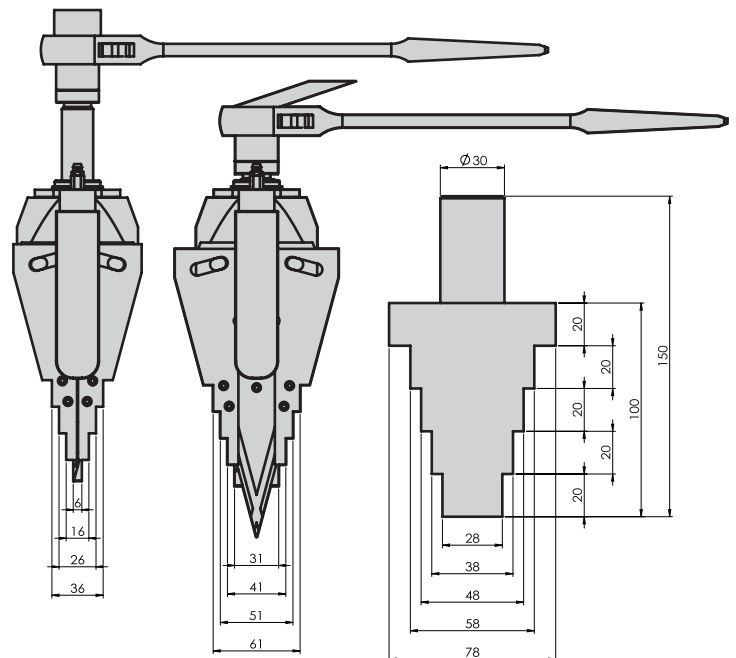

RECOMMENDED PUMP

Type	Model #	Oil Capacity (in ³)	Oil Port
Manual Single Speed	P601S	37	3/8"-18
Manual Double Speed	P352	21.4	3/8"-18
Manual Foot Pump	P570FP	30.5	3/8"-18
Air Pump	PA600	36.6	3/8"-18

SPECIFICATIONS

Model Number	Type	Capacity (Ton)	Stroke	Tip Clearance	Max. Spread	Oil Capacity (in ³)	Weight (lbs)
HFSS14	Hydraulic	14	1.56"	0.23"	1.22"	4.48	22.2
MFSS08	Mechanical	8	1.56"	0.23"	1.22"	N/A	20.7